

BARRA 400-600-800

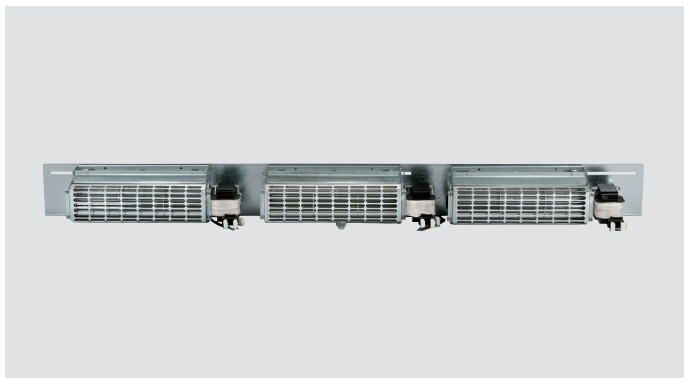

BARRA 400

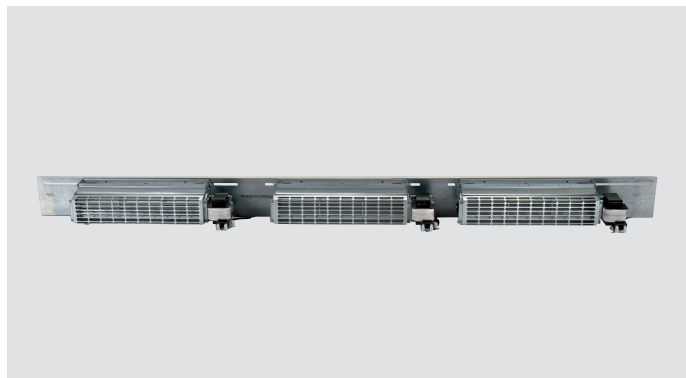

BARRA 600



BARRA 800

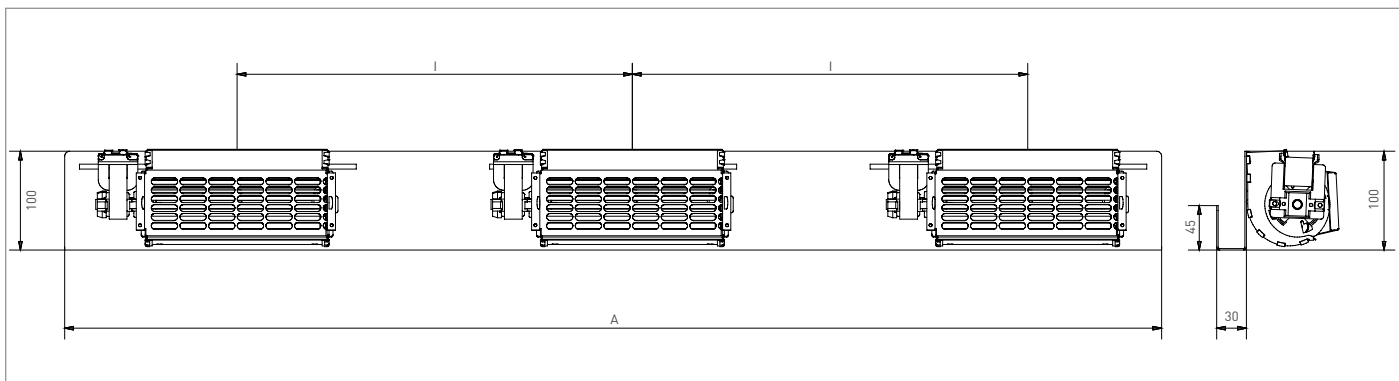

SUGGESTED APPLICATION FORM / FORME APPLICATIVE SUGGERITE

MODEL MODELLO	A (MM)	I MIN/MAX	HYPOTHETICAL TRANSFO POWER POTENZA TRAFD IPOTIZZATA	AIR FLOW PORTATA (M ³ /H)	MODEL FANS MOD. VENTILATORI
BARRA 400	1110	320-420	FROM/DA 100 AT/A 315 KVA	1020	3 X TTG240
BARRA 600	1470	430-580	FROM/DA 315 AT/A 630 KVA	1140	3 X TTG300
BARRA 800	1470	445-565	FROM/DA 630 AT/A 1250 KVA	1020	3 X TTG360

Special versions / Versioni speciali:
On demand / Su richiesta